

Model FS4000

Features

- Mass flow range from 0 ~ 2 SLPM to 0 ~ 50 SLPM
- Response time 10 ms, excellent for critical applications
- Pressure rating up to 5 bar (73 psi)
- Exchangeable mechanical connectors for easy installation at different applications
- Compact design ready for multiple channel assembly
- Excellent for electronic meters in anesthesia equipment



Description

The FS4000 mass flow sensors are manufactured using Siargo's proprietary MEMS flow sensor and package technology. The products are designed for reliability with excellent performance in targeted applications. The sensors are housed in 3mm and 8mm pipes with maximum flow rate 5 SLPM and 50 SLPM, respectively. Each model is manufactured via specially designed package and smart electronics so that the optimal sensitivity would be achieved.

The packaging enclosure is made of the chemically inert and thermally stable polycarbonate material. The maximum over pressure rating can reach up to 5 bar (73 psi) that is benefitted from Siargo's unique MEMS sensor chip structure, special packaging technology and the rugged sensor housing.

The mechanical structure of FS4000 series is designed for easy assembly as manifold for process

gas monitoring and control. Models of FS4003 are packaged in a flow channel diameter of 3 mm with a very low pressure loss configuration and measures air flow up to 5 SLPM. Applications include leakage detection, particle counter and analytical instrumentation. FS4008 are packaged in a flow channel diameter of 8 mm and measures air flow up to 50 SLPM. It can be used in gas flow measurement and/or control equipment. Applications include electronic flow meter for anesthesia equipment, clean room gas flow monitoring, air sampler, and gas analyzer.

The FS4000 sensors require a power supply of 8 ~ 18 Vdc and provide an analog output or both an analog and a digital outputs. The analog output is linearized from 0.5 Vdc to 4.5 Vdc corresponding with flow rate from 0 to full scale. The digital output can be found in

Working Principle

The MEMS sensor chip utilizes the calorimetric principle. It is packaged on a plate installed inside the flow channel, which provides additional flow conditioning from the boundary layer configuration resulting in a laminar flow. The mass flow measurement is established as the gas carries heat away from the heater leading to the redistribution of the temperature field. Accurate flow rate is obtained by calibration with standard gas at preset conditions.

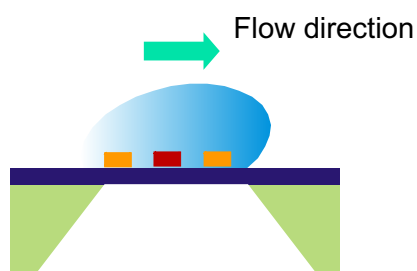

Time-averaged velocity profile boundary layer

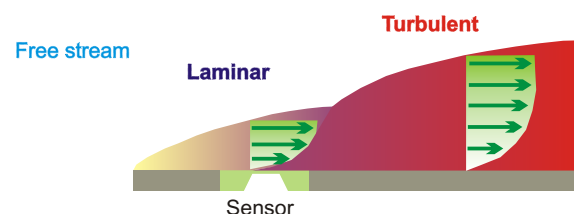

深圳市新世联科技有限公司

the communication protocol described late in this manual. The response time of the FS4000 is 10 ms by default, which provides solutions for critical applications where instant flow rate changes to be monitored. However, if slower response time is preferred, then it can be modified through RS232/RS485 communication protocol.

The mechanical interface provides options of BSPT

thread and one-touch connectors. They are readily interchangeable, which provides easy installation for different connection requirements.

The calibration is generally performed with nitrogen at 20°C and 101.325kPa pressure rating. It can nonetheless be carried out with other gases and conditions upon requests.

Block Diagram

The functional block diagram is shown in the following figure. The critical component of the FS4000 is the MEMS sensor chip. The sensor driving circuitry sends flow rate related voltage to ADC. The micro-controller processes (amplifies, filters, etc) the voltage and then

converts the voltage into flow rate. The flow rate signal is sent out through analog or both analog and digital formats (RS232 or RS485).

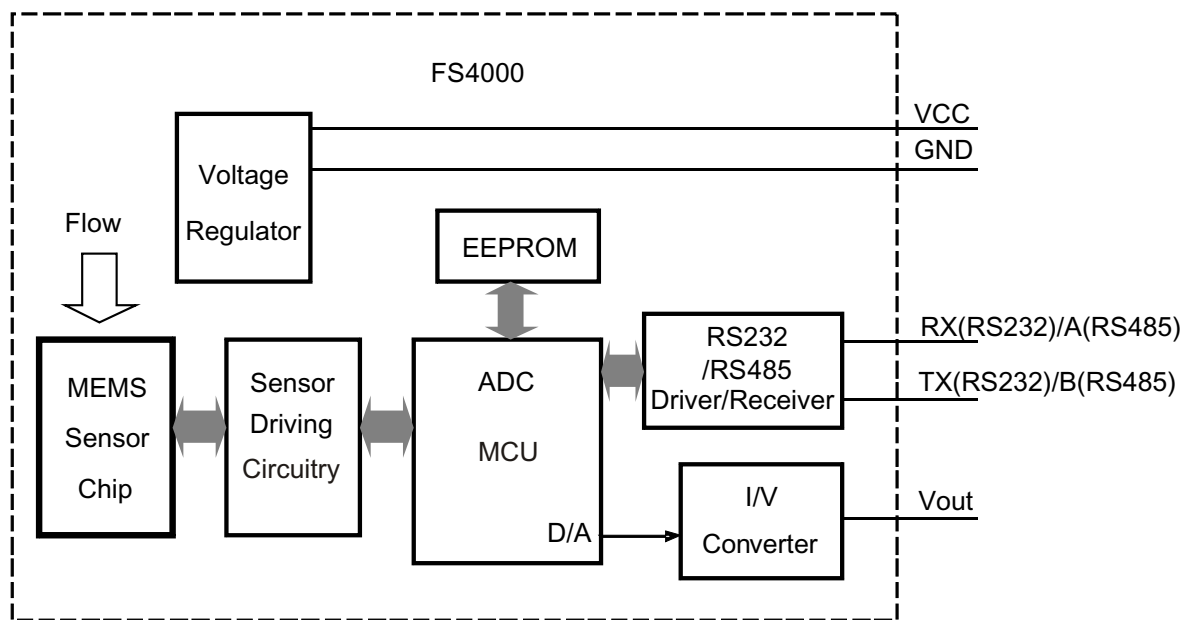

Functional block diagram of the FS4000.

深圳市新世联科技有限公司

1. Sensor Performance

1.1 Performance Specifications

All data unless otherwise noted apply for calibration conditions: N₂, 20 °C, 101.325 kPa absolute pressure, horizontal mounting.

Model	FS4003	FS4008	
Flow Range	0 ~ 2, 3, 4, 5	0 ~ 10, 20, 30,40,50	SLPM
Turn-down Ratio	> 100:1		
Accuracy ¹	± (1.5 + 0.2FS)		%
Repeatability	± 0.75		%Reading
Null Shift	± 30		mV
Output Shift	± 0.12		%/°C
Response Time ²	10 (Default, 50, 100, 200 ,500, 1000 selectable)		ms
Output ³	Linear: Analog 0.5 ~ 4.5 Vdc / Digital RS232 or RS485		
Pressure Drop (Max.) ⁴	< 100	< 600	Pa
Max. Working Pressure	0.5		MPa
Power Supply ⁵	8 ~ 18 Vdc, 50 mA		
Operating Current ⁶	24 typical when RS232/RS485 not connected		mA
	27 typical when RS232/RS485 communicates with a PC		
Power Consumption	< 220		mW
Analog Output Load	Sourcing: 25		mA
	Sinking: 15		
Working Temperature	-10 ~ +55		°C

1 Denotes ±(1.5 %Reading + 0.2 % Full Scale). To obtain accurate flow measurement, let the sensor warm up 1 minute at power up.

2 The default response time is 10ms. It can be programmed via RS232/RS485 communication port.

3 The analog output is provided and the RS232/RS485 is optional. The analog voltage 0.5 ~ 4.5 Vdc corresponds with flow rate of 0 ~ full scale. RS232 protocol can be found at the Appendix, and the RS485 can be obtained from the manufacturer.

4 The maximum pressure drops measured at flow rates of 5 SLPM and 50 SLPM for FS4003 and FS4008 respectively. See section 1.4 for details.

5 One DC power supply is necessary. The required minimum output current is 50 mA. The sensor actually consumes less than that in operation.

6 The operating current over the entire supply voltage range of 8 ~ 18 Vdc is about the same when no analog output load.

Compliance Statement: All components of this product are RoHS compliant. The product fully complies with CE norm EN61000-6-1 through 61000-6-4, EN50081-2 through 50082-2 and EMC directive 89/336/EEC.

深圳市新世联科技有限公司

1.2 Additional Specifications

Model	FS4003/FS4008		Unit
Mechanical Connection ¹	BSPT 1/4 (R 1/4), 4 mm/6 mm/8 mm One-touch		
DN	3 (FS4003) and 8 (FS4008)		mm
Pins Out ²	5 Pins, AMP 103956-4, 0.5 m		
Calibration Options ³	Air, CO ₂ , N ₂ , O ₂ , Ar @ 20 °C, 101.325 kPa		
Package Material	Polycarbonate		
Size	< 98.0 x 48.0 x 20.0		mm ³
Weight	52 (with BSPT 1/4 (R1/4) connection)		g
	71(with O4, O8 connection)	68(with O6 connection)	
Storage Temperature	-20 ~ +65		°C
Humidity	< 95 %RH (No icing or condensation)		

1 The BSPT connector and one-touch connector are interchangeable.

2 The 0.5m output cable is usually shipped together with the sensor.

3 Calibrations at other gases and conditions available upon request.

1.3 Flow Characteristics

1.3.1 Analog Output Characteristics

The FS4000 provides an analog output of 0.5 ~ 4.5 Vdc corresponding with 0 ~ full scale flow rate. Using full scale of 5 SLPM as an example, the typical analog output v.s. flow rate is illustrated in Table 1.1 and Figure 1.1.

Table 1.1: Typical output voltage v.s. flow rate.

Flow Rate (SLPM)	Typical Voltage (Vdc)
0.0	0.5
1.0	1.3
2.0	2.1
3.0	2.9
4.0	3.7
5.0	4.5
5.5	4.9
6.0	4.9

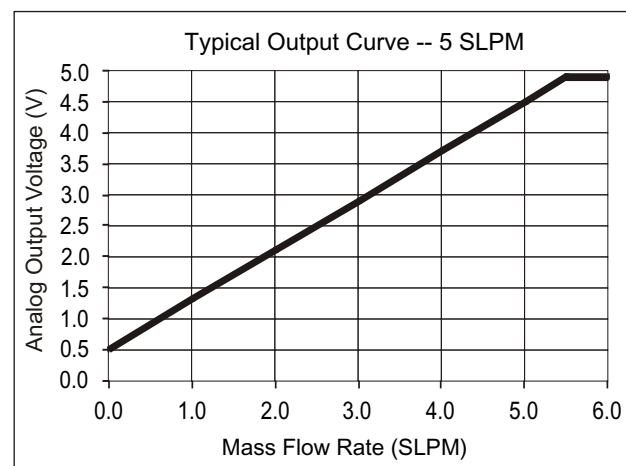

Figure 1.1: A typical analog output curve.

The sensor is calibrated 10% above the full scale flow rate to ensure the accuracy within the defined full range during interpolation. For example, full scale 5 SLPM is calibrated till 5.5 SLPM. Hence at a flow rate beyond the defined full scale, there is still analog output but the accuracy is not guaranteed.

深圳市新世联科技有限公司

2. Pins and Interface

2.1 Pin Definition

The FS4000 provides a 5-pin interface. The output connecting cable of 0.5m long is shipped together with the sensor. The sensor pin layout is shown in Figure 2.1 and the cable color code is defined in Table 2.1.

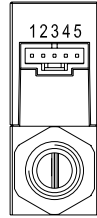

Figure 2.1: FS4000 pin layout.

Table 2.1: FS4000 cable color code.

Pin#	Color	Definition
1	Blue	TX (RS232 transmit) /A (RS485)
2	Green	Vout, Analog output
3	Red	VCC, Power supply
4	Black	GND, Ground
5	Yellow	RX (RS232 receive) /B(RS485)

2.2 Pin Description

VCC and GND: The FS4000 requires a power supply of 8 ~ 18 Vdc. The voltage is internally regulated to power the circuit. Therefore, there are no stringent requirements on the accuracy, stability as well as ripple of the power supply. The sensor consumes less than 30 mA normally but a 50 mA is required for the power supply to ensure a sufficient working current.

Vout: The analog output pin provides 0.5 ~ 4.5 Vdc corresponding with the specified flow range 0 ~ full scale. Beyond this range, there is still voltage reading, but the accuracy is not guaranteed.

TX and RX: The RS232 communication is bi-directional. TX is the transmit pin for RS232 and it sends out signal from the sensor. RX is the receive pin and it receives signal. Using these two pins together with GND pin, the sensor's operation mode and response time can be configured, and the voltage as well as flow rate can be obtained.

A and B: The RS485 is an asynchronous, half-duplex communication. A is the transmit pin for RS485 and it sends out signal from the sensor. B is the receive pin and it receives signal. When transmitting signal from the sensor, or receiving signal, the other pin is working as GND.

3. Mechanical Dimensions and Mountings

3.1 Sensor Mechanical Dimensions

The FS4000 provides two options to mechanically interface with customer applications: BSPT 1/4 (R 1/4) thread and one-touch connectors, and they are readily interchangeable. The dimensions are shown in Figure 3.1 and Figure 3.2.

For BSPT 1/4 (R 1/4) connection:

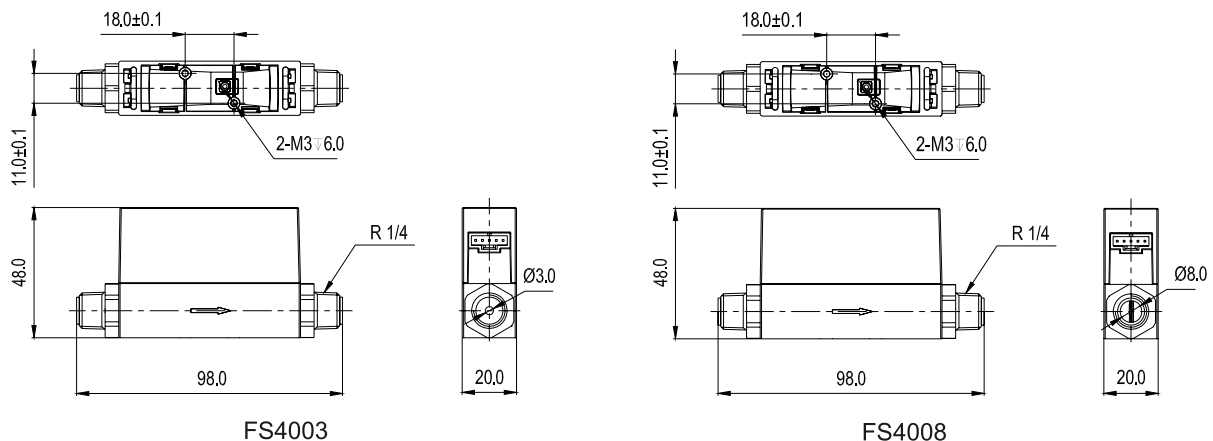

Figure 3.1: The FS4000 mechanical dimensions with BSPT 1/4 (R 1/4) connectors.

深圳市新世联科技有限公司

1.3.2 Digital Output Characteristics

The digital output is accessed via RS232/RS485. Figure 1.2 shows the applied mass flow rate v.s. the digital output of a 50 SLPM full scale sensor. Same as analog output, when flow rate is beyond the defined full scale, the output accuracy is not guaranteed.

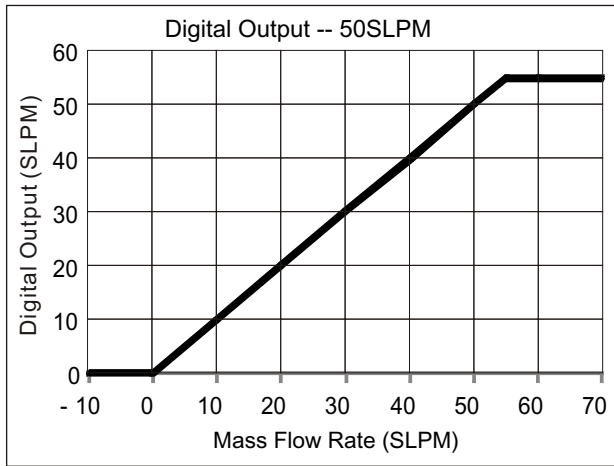

Figure 1.2: Typical digital output characteristics.

1.4 Pressure Drop Characteristics

The FS4000 is packaged with standard enclosures with flow channel sizes of 3 mm and 8 mm, respectively, for different applications. The pressure drop is influenced by the flow channel size as well as the flow rate applied. For FS4003, the maximum pressure drop is measured at flow rate 5 SLPM, and 50 SLPM for FS4008. The results are shown in Table 1.2, 1.3 and Figure 1.3, 1.4.

Table 1.2: FS4003 pressure drop v.s. flow rate.

Flow Rate (SLPM)	0	1	2	3	4	5
Pressure Drop (Pa)	0	6	15	30	55	95

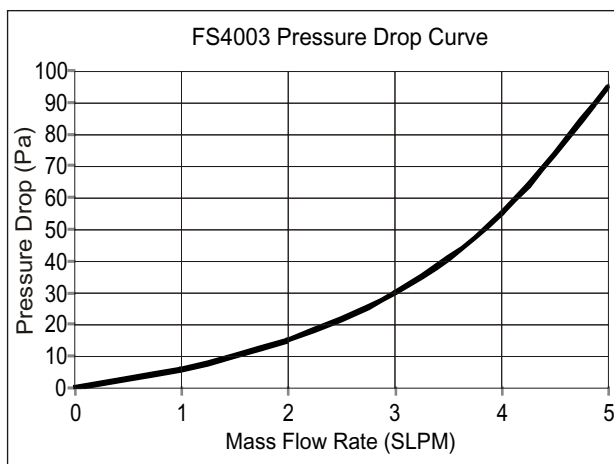

Figure 1.3: FS4003 pressure drop v.s. flow rate.

Table 1.3: FS4008 pressure drop v.s. flow rate.

Flow Rate (SLPM)	0	5	10	20	30	40	50
Pressure Drop (Pa)	0	8	25	90	200	370	580

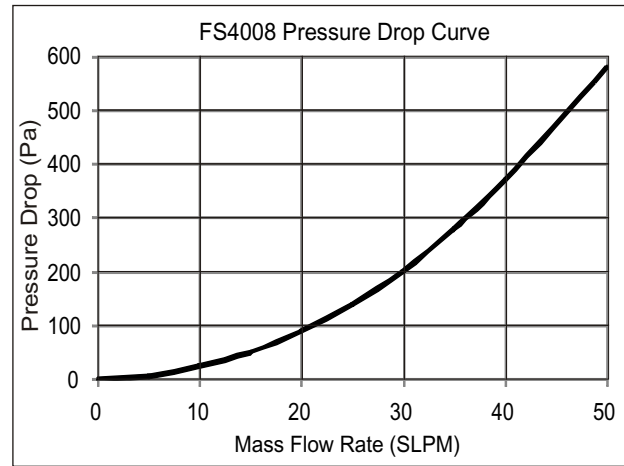
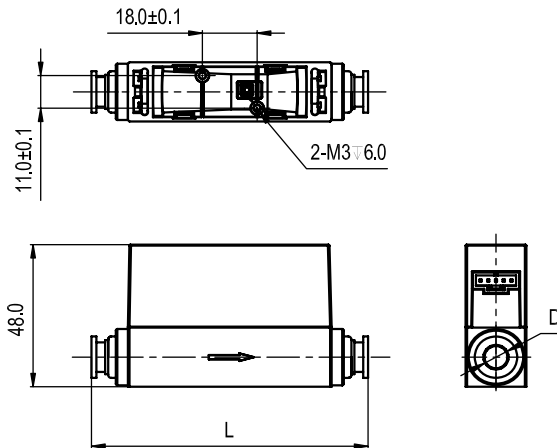

Figure 1.4: FS4008 pressure drop v.s. flow rate.

深圳市新世联科技有限公司

For one-touch connection:



One-touch Connection	L	D
ID=8mm	91.0	Φ8.0
ID=6mm	83.0	Φ6.0
ID=4mm	80.0	Φ4.0

Figure 3.2: The FS4000 mechanical dimensions with one-touch connector.

4. Ordering Guide

4.1 Sensor Selection

The sensor part number is composed of the product model number and suffix indicating the full scale flow rate, mechanical connection, output format as well as the application gas. Refer the following for details.

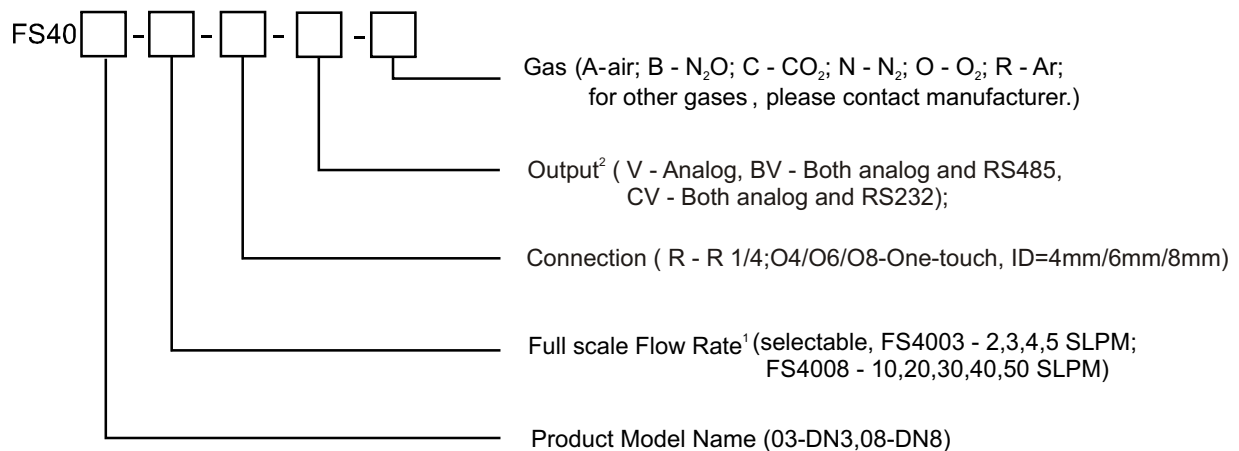

1 Max. flow rate number only, for example, 30 meaning full scale flow rate of 30SLPM.
 2 The sensor shipped with standard analog output. RS232/RS485 is optional.

4.2 Order Contact and Customer Support

The sales offices are listed at the end of this document. For small quantities, the order can be placed either through Siargo website: www.siargo.com or the sales offices. For large quantities, please contact the sales offices or the authorized distributors or sales representatives.

Siargo is making every effort to ensure the quality of the products. In case of questions, and or product supports, please contact customer service listed at the end of the document. We will respond your request in a timely fashion and will work with you toward your complete satisfaction.

深圳市新世联科技有限公司

Important Notices

Wetted Materials and Compatibility

The sensor body is made of medical compatible plastics. The sensor chip comprises of silicon, silicon nitride and silicon dioxide and the sensor chip surfaces are passivated with silicon nitride and silicon dioxide. The electronic sealing is provided by RTV (room temperature vulcanizing) silicone sealant WR-704 composed of $\text{HOCH}_3(\text{SiO})_n\text{CH}_3\text{H}$.

Cautions for Handling and Installations

The product at the time of shipment is fully inspected for product quality and meets all safety requirements. Additional safety measures during handling and installation should be applied. To prevent ESD (electrostatic discharge) damage and /or degradation, take customary and statutory ESD precautions when handling. Do power the product with the correct polarity, voltage and amperage. All precautions and measures for electrical voltage handling must apply. The product sealing is ensured to work under working pressure of 0.5MPa and is leakage proof before the shipment. But cautions and further leakage test are important at installation as well since any leakage might cause severe safety issue.

This product contains no user serviceable components. Do not attempt to disassemble, substitute parts or perform unauthorized modifications to the product. Doing so will forfeit the terms of the warranty and cause the liability to any damages thereafter. It should only be serviced by authorized personnel. Upon requests, Siargo will provide necessary technical support and/or training of the personnel.

Cautions for Product Applications

The product is designed for use with general purpose gases such as air and nitrogen. It is advised that the products are best used for non-explosive clean gases. The sensors cannot be used for gas metrology of fluoride or fluoride-containing gases. For updates of the product certification information, please contact the manufacturer. Use for other gases such as extreme corrosive and toxic gases may cause the product malfunctioning or even severe damages.

Don't expose the product's outer surface to any liquids, the unit does not have a water tight electronics package.

Don't flow gas in conditions that can cause water condensation or water trap inside the unit as the accuracy could be significantly altered.

It is suggested to design your application so that

nominal flow rate is approximately 70% of the full scale flow rating of the sensor. Don't use a sensor with a flow range beyond the specification continuously. Select the product properly, and do not use high flow sensor for trace flow applications. For instance, don't use a 50 SLPM sensor for a 0.5 SLPM application as the accuracy would not be desired.

Warranty and Liability

(effective May 2009)

Siargo warrants the products sold hereunder, properly used and properly installed under normal circumstances and service as described in the user manual, shall be free from faulty materials or workmanship for 180 days for OEM products, and 365 days for non-OEM products from the date of shipment. This warranty period is inclusive of any statutory warranty. Any repair or replacement serviced product shall bear the same terms in this warranty.

Siargo makes no other warranty, express or implied and assumes no liability for any special or incidental damage or charges, including but not limited to any damages or charges due to installation, dismantling, reinstallation or any other consequential or indirect damages of any kind. To the extent permitted by law, the exclusive remedy of the user or purchaser, and the limit of Siargo's liability for any and all losses, injuries or damages concerning the products including claims based on contract, negligence, tort, strictly liability or otherwise shall be the return of products to Siargo, and upon verification of Siargo to prove to be defective, at its sole option, to refund, repair or replacement of the products. No action, regardless of form, may be brought against Siargo more than 365 days after a cause of action has accrued. The products returned under warranty to Siargo shall be at user or purchaser's risk of loss, and will be returned, if at all, at Siargo's risk of loss. Purchasers or users are deemed to have accepted this limitation of warranty and liability, which contains the complete and exclusive limited warranty of Siargo, and it shall not be amended, modified or its terms waived except by Siargo's sole action.

This warranty is subject to the following exclusions:

- (1) Products that have been altered, modified or have been subject to unusual physical or electrical circumstances indicated but not limited to those stated in this document or any other actions which cannot be deemed as proper use of the products.
- (2) Siargo does not provide any warranty on finished goods manufactured by others. Only the original manufacturer's warranty applies;
- (3) Products re-sold to the third parties.

深圳市新世联科技有限公司

Appendix RS232 Communication Protocol

Serial Port Settings

Physical interface	TIA/EIA-232-E			
Transmission cable	3-core shielded cable			
Cable length	≤ 3m			
Communication interface	UART, Half-duplex			
Data link protocol	Point to point			
Port Setting	Baud rate (Bits per second)	38400 bps		
	Data bits	8 bits		
	Parity	Frame_header	1 bit	Mark
		Others		Space
	Stop bits	1 bit		
	Flow control	None		
Error checking method	XOR			

Protocol Structure

This protocol includes three working layers: physical layer, data link layer, and user layer.

Physical layer protocol

Every byte contains 11bits, which is defined as follows:

Start_bit D0 D1 D2 D3 D4 D5 D6 D7 D8 Stop_bit

- a) Start_bit:
1bit, a logic low;
- b) Data bits (D0~D7):
8 bits, representing the data byte under transmission, which is ordered from the least-significant digit to the most-significant digit;
- c) Frame_header flag (D8):
1bit, a flag to indicate whether the data byte under transmission is a type of datum or frame_header.
* When transmitting a frame_header (or address) from master, D8 must be set to 1. When transmitting another datum (such as command code, data length, data segment, checksum or frame_end), D8 can be set to 0, or 1. We suggest customer set D8 to 0, when transmitting other datum;
* For the byte sent from FS4000, D8 is always 0;
- d) Stop_bit:
1bit, a logic high.

Data link layer protocol

Both the master and slave (e.g., FS4000) have the same frame format, each byte of which is hexadecimal (non-ASCII code). Specifically, the frame format is

defined as below:

Frame_header	1 byte
Command code	1 byte
Length	1 byte
Data	Variable-length
Checksum	1 byte
Frame_end	1 byte

- a) Frame_header:
0x9D;
- b) Command code:
The command code, an integer between 0 and 255 excepting 0x9D, defined in the User Layer to achieve various functionality.
- c) Length:
The length of the data, an integer between 0 and 102 depending on the command code. If the command code has no data, the length should be 0. If the FS4000 unit detects the length larger than 102, the FS4000 unit will not send any response;
- d) Data:
The body of the data, whose length varies depending on the command code. If the command code has no data, the length should be 0;
- e) Checksum:
XOR;
- f) Frame_end:
0x0D;
- g) Overtime
1sec. This is to prevent FS4000 from running into a deadlock because of the master failures or communication failures. When FS4000 receives a correct byte, a timer will begin. If FS4000 does not receive other correct byte within 1sec, it will interrupt the communication and prepare to receive next byte. The interval time from FS4000 to the master is less than 10msec (which can be used for the master to judge the overtime).

User layer protocol

Command Code	F0	Read instant flow rate
Master query	9D F0 01 08 CRC 0D	
FS4000 response	9D F0 03 FRH FRM FRL CRC 0D	
Description	3 bytes.	FR (Instant flow rate) = (FRH * 65536 + FRM * 256 + FRL) / 1000; Unit: SLPm, Decimal digits: 3.
Command Code	FF	Read the sensor series number
Master query	9D FF 00 CRC 0D	
FS4000 response	9D FF 0C SN1 SN2 SN3 SN4 SN5 SN6 SN7 SN8 SN9 SN10 SN11 SN12 CRC 0D	
Description	12 bytes.	It is the series number of the sensor made up of 12 ASCII characters.

深圳市新世联科技有限公司

Appendix RS232 Communication Protocol

User layer protocol (continued)

Command Code	02	Change the response time
Master query	9D 02 02 RTH RTL CRC 0D	
FS4000 response	9D 02 01 STATE CRC 0D	
Description	1 byte. Unit: msec. $RT (\text{ response time }) = RTH * 256 + RTL$; Selectable: 10, 50, 100, 200, 500 and 1000. STATE: if the operation is successful, STATE = 1, otherwise STATE = 0.	
Command Code	03	Change the GDCF of the sensors
Master query	9D 03 02 GDCFH GDCFL CRC 0D	
FS4000 response	9D 03 01 STATE CRC 0D	
Description	1 byte. $GDCF = GDCFH * 256 + GDCFL$. STATE: if the operation is successful, STATE = 1, otherwise STATE = 0.	
Command Code	72	Calibrate the offset of the sensor (Auto)
Master query	9D 72 01 55 CRC 0D	
FS4000 response	9D 72 02 OFFSETH OFFSETL CRC 0D	
Description	2 bytes. Ensure there is no flow in the sensor pipe during calibrating offset. $Offset = OFFSETH * 256 + OFFSETL$. The normal range is from -32767 to +32767.	
Command Code	78	Reset all the parameters to default.
Master query	9D 78 01 55 CRC 0D	
FS4000 response	9D 78 01 STATE CRC 0D	
Description	1 byte. Reset all the parameters to default (Automatic) 1, Reset the default response time (10msec); 2, Reset the default GDCF (1000); 3, Reset the default offset.	
Command Code	82	Read the response time
Master query	9D 82 00 CRC 0D	
FS4000 response	9D 82 02 RTH RTL CRC 0D	
Description	2 bytes. $RT (\text{ response time }) = RTH * 256 + RTL$:	
Command Code	83	Read GDCF
Master query	9D 83 00 CRC 0D	
FS4000 response	9D 83 02 GDCFH GDCFL CRC 0D	
Description	2 bytes. $GDCF = GDCFH * 256 + GDCFL$.	

Flow chart (master to FS4000)

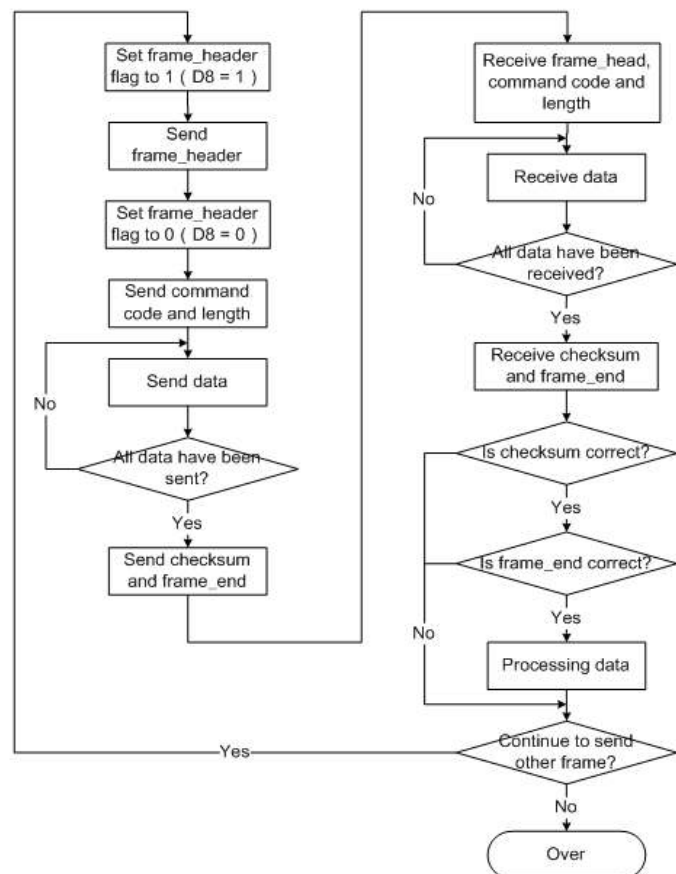

深圳市新世联科技有限公司